

Variante Federvorschub rechts (Standard)

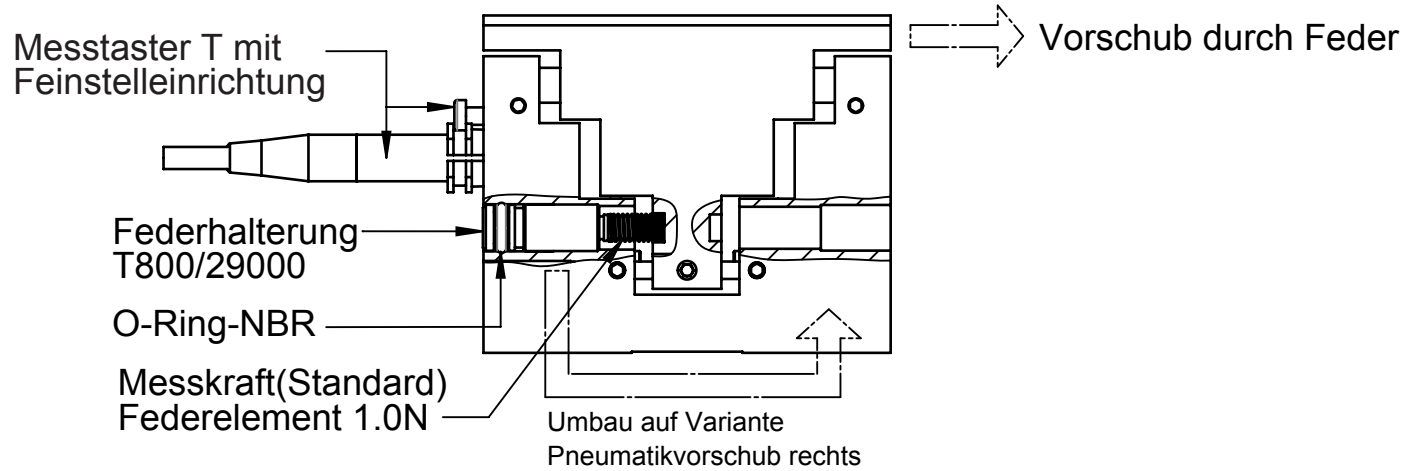

Variante Pneumatikvorschub rechts

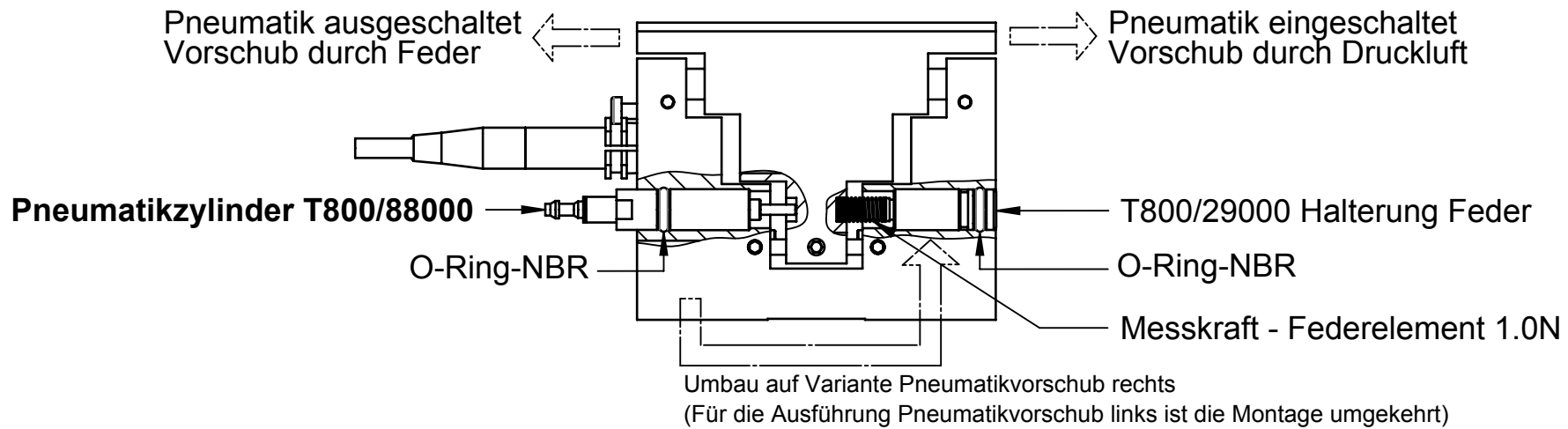

1002214

Montagezeichnung
Pneumatikzylinder T800/88000

Masstab / Scale

1:1.5

mm

